

DESCRIPTION

The MS3701 is a slim, plug-in thermocouple temperature transmitter that converts input signals from a thermocouple into commonly used DC signals and provides isolated single or dual output.

ORDERING CODE

MS3701 - -

Model _____

Power Supply _____

A: 100 to 240V AC (50 to 60Hz)
D: 24V DC **P:** 100 to 240V DC

Input _____

K: Type K thermocouple **B:** Type B thermocouple
E: Type E thermocouple **R:** Type R thermocouple
J: Type J thermocouple **S:** Type S thermocouple
T: Type T thermocouple **N:** Type N thermocouple
0: Other than those above.

Output 1 _____

A: 4 to 20mA DC **1:** 0 to 10mV DC
D: 0 to 20mA DC **2:** 0 to 100mV DC
Z: Other DC current signal **3:** 0 to 1V DC
 4: 0 to 10V DC
 5: 0 to 5V DC
 6: 1 to 5V DC
 3W: ±1V DC
 4W: ±10V DC
 5W: ±5V DC
0: Other DC voltage signal

Output 2 _____

No code: None
The codes are the same as for Output 1.

Note 1: When a voltage output is selected for Output 1, a current output cannot be selected for Output 2.
Note 2: When the code A (4 to 20mA) is selected for both of the two outputs, the output load will be 550Ω maximum for Output 1 and 350Ω maximum for Output 2.
Note 3: Upscale burnout protection is standard.

Options _____

No code: None
/D: Downscale burnout protection
/K: Fast response (0 to 90% response time: 10ms max.)
/L: Dual current output with high output load
 *Not subject to CE approval.
 (OUT-1: 750Ω / OUT-2: 550Ω)
/X: Others (Special order)
* For non-standard options, ask MTT for availability.

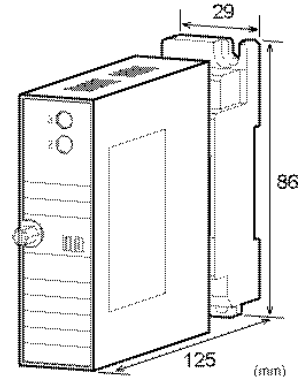
ORDERING INFORMATION

To place an order, please use the ordering code format as shown on the left. Also specify a measuring temperature range.
(e.g.) MS3701-A-KAA (0 to 500°C)

* Note that the temperature range should be specified in steps of at least 10 degrees Celsius.

Other Ordering Examples:
For an input code of "0": MS3701-A-0AA (WRe5-26 0 to 2000°C)
For an output code of "0": MS3701-A-K60 (0 to 500°C / Output: 2 to 5V)
For an option code of "X": MS3701-A-K66/X (0 to 500°C / Burnout Drive Time: 500ms max.)
Note: If you wish to include multiple options in your order, specify the option codes in series (e.g. /KX).

SPECIFICATIONS

●POWER SECTION			
Power Requirements	100 to 240V AC: 85 to 264V AC (47 to 63Hz)		
	24V DC: 24V DC±10%		
	100 to 240V DC: 85 to 264V DC		
Power Sensitivity	Better than ±0.1% of span for each power supply range.		
Power Line Fuse	160mA fuse is installed (standard).		
Power Consumption			
Power	100-240V AC	24V DC	100-240V DC
Single Output	5.5VA max	1.5W max	6.0W max
Dual Output	7.0VA max	1.8W max	6.0W max
●INPUT SECTION			
Input Resistance	With or without power: 1MΩ min.		
Allowable Signal Source Resistance	1kΩ max.		
Input Voltage	30V DC max., continuous.		
Cold Junction Compensation	A built-in temperature-sensitive resistor is used.		
Cold Junction Compensation Error	±0.5°C max. (25°C±15°C)		
Linearizer	Built-in analog linearizer (6 segments maximum)		

Ranges Available
<Standard specifications> (Temp at 0% input = 0°C)

K	Specify between 0-100°C and 0-1350°C in steps of 50°C (e.g. K 0 to 350°C).
E	Specify between 0-100°C and 0-1000°C in steps of 50°C (e.g. E 0 to 150°C).
J	Specify between 0-100°C and 0-800°C in steps of 50°C (e.g. J 0 to 550°C).
T	Specify between 0-100°C and 0-400°C in steps of 50°C (e.g. T 0 to 250°C).
B	Specify between 0-1200°C and 0-1800°C in steps of 100°C (e.g. B 0 to 1700°C).
R	Specify between 0-400°C and 0-1700°C in steps of 100°C (e.g. R 0 to 1400°C).

<Quasi-standard specifications>

Type	Temperature Range (°C)	(+) Bias	(-) Bias
K	-200 to +1370	Up to 5x input span.	Up to 1x input span.
E	-200 to +1000	Up to 3x input span.	Up to 0.5x input span.
J	-200 to +1200	Up to 5x input span.	Up to 0.5x input span.
T	-200 to +400	Up to 2x input span.	Up to 0.5x input span.
B	0 to +1820	Up to 5x input span.	N/A
R	-50 to +1760	Up to 10x input span.	No limitation.
S	-50 to +1760	Up to 10x input span.	No limitation.
N	-200 to +1300	Up to 5x input span.	Up to 0.5x input span.

Input Spec Ex. 1: For K -100 to 400°C, the input span is 500°C and the bias -0.2x the input span.

Input Spec Ex. 2: For J 300 to 400°C, the input span is 100°C and the bias 3x the input span.

Note 1: Input span: 3mV min.

Note 2: For input temperature ranges starting from any specified temperature below 0°C, the accuracy may be partly out of specification.

Note 3: For the type B thermocouple, the accuracy in the temperature range below 600°C is not guaranteed.

Note 4: Any specification out of the temperature range or bias requirement listed above is handled as a special order.

● OUTPUT SECTION

Maximum Output Load

Voltage Output (DC)	1V span and up	2mA max. 10kΩ min.
Current Output (DC)	100mV	100kΩ min.
	4-20mA single output	750Ω max.
	4-20mA dual output	Output 1: 550Ω max. Output 2: 350Ω max.
Zero Adjustment	Approx. ±5% of span. (Adjustable by the front-accessible trimmer.)	
Span Adjustment	Approx. ±5% of span. (Adjustable by the front-accessible trimmer.)	
Burnout Protection	Standard: Upscale (Downscale is optional.)	

Ranges Available

	Current Signal	Voltage Signal
Output Range (DC)	0 to 20mA	-10 to 10V
Output Span (DC)	4 to 20mA	10mV to 20V
Output Bias	0 to 100%	-100 to 100%

* For current output signals, the accuracy of any current output smaller than 0.1mA is not guaranteed.

Output Spec Ex. 1: For 4 to 20mA output, the output span is 16mA and the bias +25%.

Output Spec Ex. 2: For -1 to 4V output, the output span is 5V and the bias -20%.

● PERFORMANCE

Accuracy Rating

Better than ± [0.1% of span + 0.5°C {Cold junction compensation error} + Linearity error] (at 25°C±5°C)

Note: Linearity errors vary with input spans.

Input Span	Linearity Error (%)	Input Span	Linearity Error (%)
JIS K 0-300°C	0.1	JIS K 0-600°C	0.15
JIS J 0-200°C	0.15	JIS E 0-200°C	0.15
JIS E 0-600°C	0.25	JIS R 0-1600°C	0.5
JIS S 0-1000°C	0.25	JIS T 0-300°C	0.25

Temperature Effect	Better than ±0.2% of span per 10°C change in ambient.
Response Time	160ms max. (0 to 90%) with a step input at 100%.
CMRR	100dB min. (500V AC, 50/60Hz)
Isolation	4-way isolation between input, output [Output 1/Output 2], power, and ground.
Insulation Resistance	100MΩ min. (@ 500V DC) between input, output [Output 1/Output 2], power, and ground.
Dielectric Strength	Input / Output [Output 1/Output 2] / [Power, Ground]: 2000V AC for 1 minute (Cutoff current: 0.5mA) Power / Ground: 2000V AC for 1 minute (Cutoff current: 5mA) Output 1 / Output 2: 500V AC for 1 minute (Cutoff current: 0.5mA)
Surge Withstand Capability	Tested as per ANSI/IEEE C37.90.1-1989
Operating Environment	Ambient temperature: -5 to 55°C Humidity: 5 to 90% RH (non-condensing)
Storage Temperature	-10 to 60°C

● PHYSICAL

Installation	Wall/DIN rail mounting
Wiring	M3.5 screw terminal connection (with a power terminal block cover & drop-out prevention screws)
Screwing Torque	0.8 to 1.0 [Nm] * Recommended
External Dimensions	W29 × H86 × D125mm (including the mounting screw and socket)
Weight	Main unit: 120g max. Socket: 80g max.

MATERIALS

Housing	ABS resin (UL 94V-0)
Terminal Block	PBT resin (UL 94V-0)
Terminal Block	PC resin (UL 94V-2)
Cover	
DIN Rail Stopper	PP resin (UL 94HB)
Screw Terminal	Nickel-plated steel
Contacts Material and Finish	Brass with 0.2µm gold plating
Printed Circuit Board	Glass fabric epoxy resin (FR-4: UL 94V-0)
Anti-Humidity Coating	HumiSeal® 1A27NSLU (Polyurethane)

* HumiSeal® is a registered trademark of Chase Corporation.

STANDARDS CONFORMITY

CE Directive Conformity	EMC Directive (2014/30/EU) EN61326-1: 2013 Low Voltage Directive (2014/35/EU) IEC61010-1/EN61010-1: 2010 Installation Category II Pollution Degree 2 Maximum operating voltage 300V Reinforced insulation between [input/output/GND] and power.
-------------------------	--

TERMINAL ASSIGNMENT

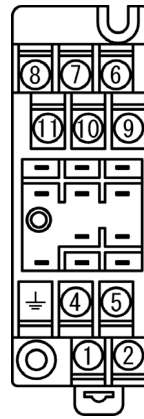

①	P (+)	POWER
②	N (-)	
⊥	GND	
④	+ OUTPUT 1	
⑤	- OUTPUT 1	
⑥	N.C.	
⑦	+ OUTPUT 2	
⑧	- OUTPUT 2	
⑨	TC +	
⑩	TC -	
⑪	N.C.	

BLOCK DIAGRAM

